

PLAN VIEW

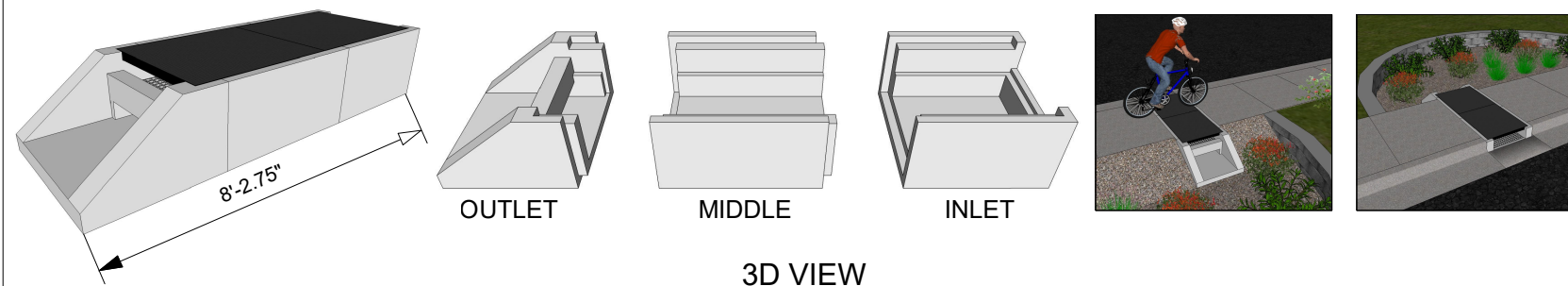

3D VIEW

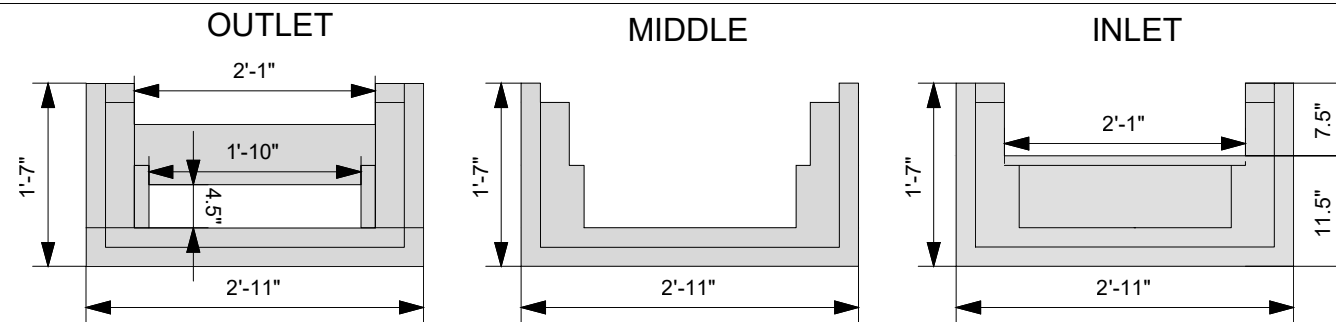

END A-A' VIEW

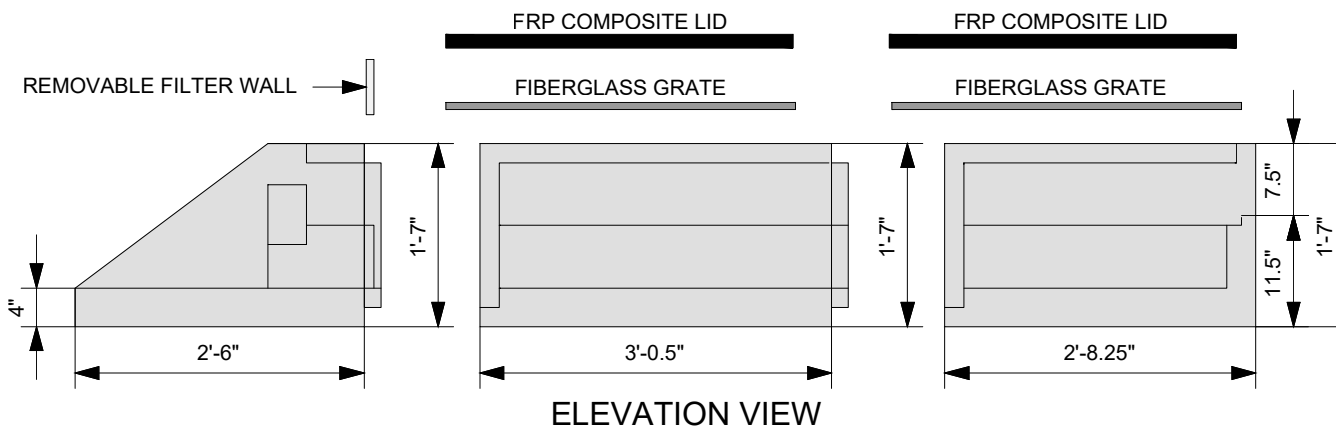

ELEVATION VIEW

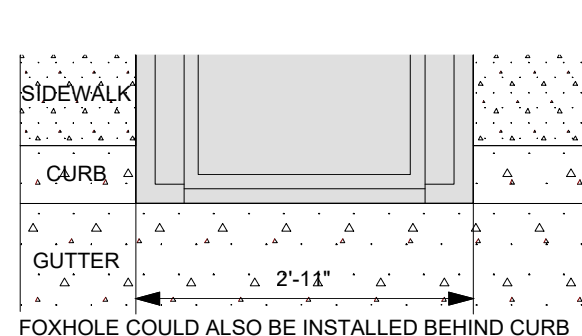

INSTALLED PLAN VIEW - INLET ONLY

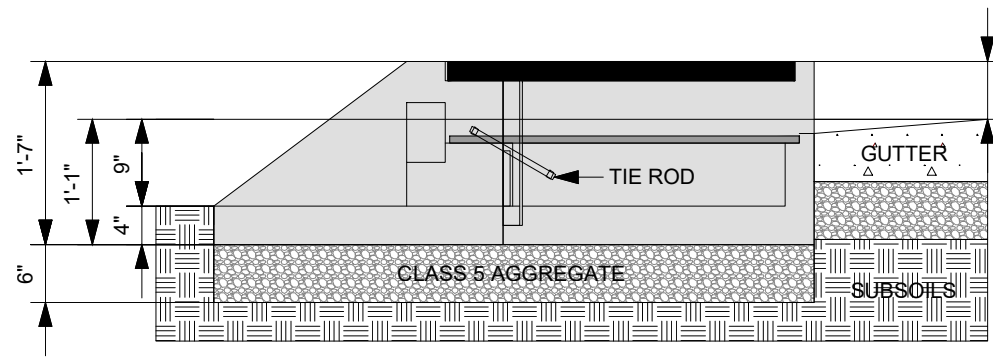

INSTALLED ELEVATION VIEW - INLET/OUTLET ONLY

**SPECIFICATIONS**

1. STEEL REINFORCED, COLD JOINT SECURED MONOLITHIC CONCRETE STRUCTURES (INLET 875 LBS, MIDDLE 965 LBS, AND OUTLET 730 LBS). CONCRETE SHALL HAVE A MINIMUM COMPRESSIVE STRENGTH OF 4,000 PSI AT 28 DAYS. CONCRETE AIR ENTRAINED (4% TO 8% BY VOLUME). MANUFACTURED AND DESIGNED TO ASTM C858.
2. 2-POINT PICK USING RECESSED LIFTING POCKETS WITH A STANDARD HOOK.
3. FIBERGLASS GRATE (11 LBS/PIECE).
4. FRP COMPOSITE LID (38 LBS/PIECE) WITH CONCENTRATED LOAD CAPACITY OF 11,200 LBS.

**INSTALLATION NOTES**

1. INSTALL A CLASS 5 BASE (COMPACTED TO 95% STANDARD PROCTOR). THE DISTANCE FROM THE BACK OF THE CURB MAY VARY BASED ON SITE CONDITIONS. EXCAVATE 1' 7" BELOW THE GUTTERLINE ELEVATION (I.E. THE BIORETENTION OVERFLOW ELEVATION) TO ACCOMMODATE THE 9" PONDING DEPTH, 6" CLASS 5 AGGREGATE, AND 4" RAIN GUARDIAN FOXHOLE BASE (INCLUDED). THEREFORE, THE TOP OF THE CLASS 5 COMPACTED BASE IS PRECISELY 1' 1" BELOW THE GUTTERLINE ELEVATION. THE TOP OF THE RAIN GUARDIAN FOXHOLE INLET POINT WILL BE 7-1/2" ABOVE THE TOP OF THE CONCRETE BASE AND 1-1/2" BELOW THE GUTTERLINE ELEVATION TO ACCOMMODATE A SLOPED INLET FROM THE GUTTER TO THE RAIN GUARDIAN FOXHOLE.
2. SET RAIN GUARDIAN FOXHOLE INLET FIRST, FOLLOWED BY MIDDLE SECTION(S), AND FINALLY THE OUTLET ON THE PREPARED CLASS 5 BASE. POSITION RAIN GUARDIAN FOXHOLE OUTLET PIECE SO PRIMARY OUTLET ALIGNS WITH TOE OF BASIN SIDE SLOPE TO AVOID SOIL INTERFERENCE WITH REMOVABLE FILTER WALL.
3. SECURE MODULAR FOXHOLE PIECES AT EACH JOINT USING PROVIDED GALVANIZED TIE RODS.
4. INSTALL EXPANSION/CONTRACTION JOINT MATERIAL OR A SHEET OF POLY TO SERVE AS A BOND BREAK BETWEEN RAIN GUARDIAN FOXHOLE AND CONCRETE INLET BEFORE POURING INLET.
5. REMOVABLE FILTER WALL SHOULD BE INSTALLED WITH FILTER FABRIC FACING THE RAIN GUARDIAN FOXHOLE INLET.



**POROUS TECHNOLOGIES, LLC**  
 888.357.1161  
 www.stormcrete.com  
 Porous Technologies, LLC  
 163 Thadus Street  
 South Portland, ME 04106  
 STORMCRETE® PATENT PENDING

**MODULAR DRY FILTER BOX**

DATE:	07/23/2020
DRAWN BY:	TJC
CHECKED BY:	KJM
SCALE:	NTS

**RAINGUARDIAN FOXHOLE**

DWG NO. **D6**